

FCS-2500/13 DATASHEET

Solid Core UHACS - Ultra High Accuracy Current Sensor

This UHACS has a high gain and measurement accuracy in the full bandwidth range, due to the application of the multi-point zero-flux technology system and high-frequency ripple sensing channel on top of currently existing DC sensor technology.



TECHNICAL SPECIFICATIONS

GENERAL CHARACTERISTICS

Primary Nominal current DC	± 2500A DC
Linear measuring range (1min)	1.1 x IPN_DC
Primary Nominal current AC	± 1750A AC (refers to AC effective value)
Nominal output signals	±40mA
Supply voltage	±24VDC (±5%)
Current consumption	±1.200mA
Galvanic isolation	5KV RMS/50Hz/min
Conversion ratio (A/mA)	2500:40
Weight	7,2 ± 0,5 kg
Protection of Case	IP65



ACCURACY

Zero offset current	±1 µA (@25 °C)
Offset temperature coefficient	25 ppm / K
Measuring resistance	250 Ohm
Response time	±20µs (di/dt of 100A/µs rise to 90% Ipn)
Accuracy	0,1% (Ipn - 0,05 Ipn)
Linearity	0,02% FS

ENVIRONMENTAL

Operating temperature	-40°C ~ +85°C
Storage temperature	-55°C ~ +95°C

DEFINITION OF PART NUMBER

FCS - 2500

Rated Input current **M** = 2500A

DIMENSIONS (MM)

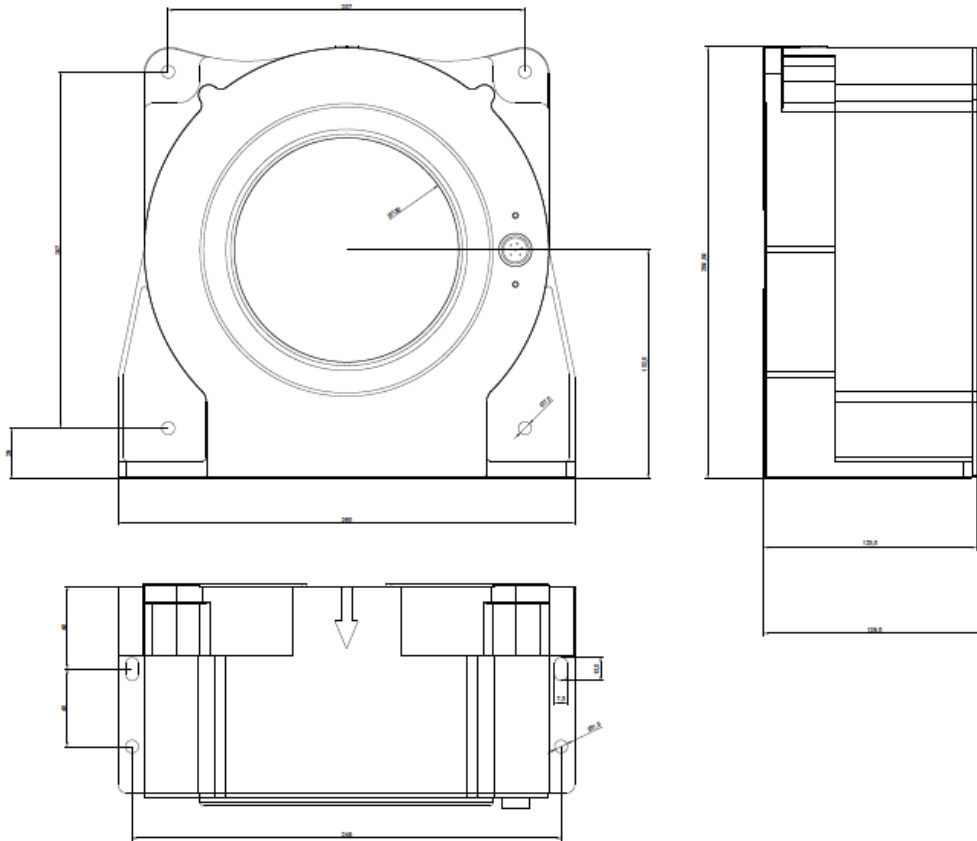

WIRING SENSORS

Pins

- 1 (+): +24V
- 2 (-): -24V
- 3 (G): 0V / Neg. Output
- 4 (M): Pos. Output
- 5 : N/A
- 6 : N/A

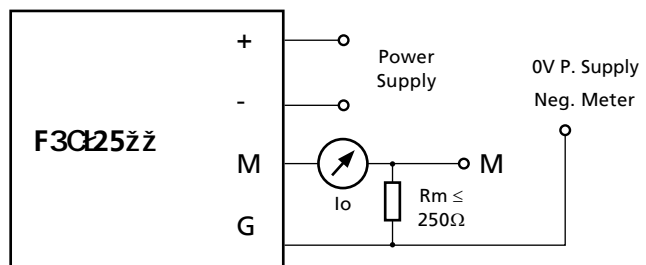
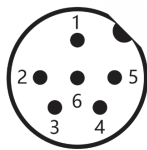

IMPORTANT NOTES



▶ **Incorrect connection may lead to the damage of the sensor.** Connect the terminals of power source and output respectively and correctly. **Please pay special attention to the 0V / Negative Current Output connection.**

▶ The best accuracy can be achieved when the window is fully filled with bus-bar (current carrying conductor).



▶ The current sensor is not allowed to be used when the secondary output is open-circuited, that is, when the primary has current or the sensor is powered on, the secondary output terminal is not allowed to be disconnected; only when the bus has no current and the sensor is not powered on, the current output terminal of the sensor can be disconnected. Otherwise, high voltage may be induced and there is a danger of electric shock or equipment damage.

▶ When you need to move the product, please be sure to cut off the power first and unplug all the connecting cables connected to it.