

PM130 PLUS Quick Start Manual

This Quick Start Manual is a short guide on how to mount, connect, configure and operate the PM130 PLUS. It is not intended to replace reading the full User Manual – and particularly the safety precautions. The manual is available on the Product Documentation CD.



Mounting, electrical connection and settings of the PM130 shall be made in accordance with all applicable laws and/or regulations and be performed by authorized personnel only.

MOUNTING

Position the PM130 meter in 92×92mm square or 4" round cutout (Figure 1). If two PM130 are positioned side by side, keep at least 150mm (5.9") between their centers to allow installation of add-on modules (140mm/5.5" if only small form modules will be used).

Attach the PM130 unit using washers and nuts. Make sure that the unit is securely attached into the wall or cabinet fixture.

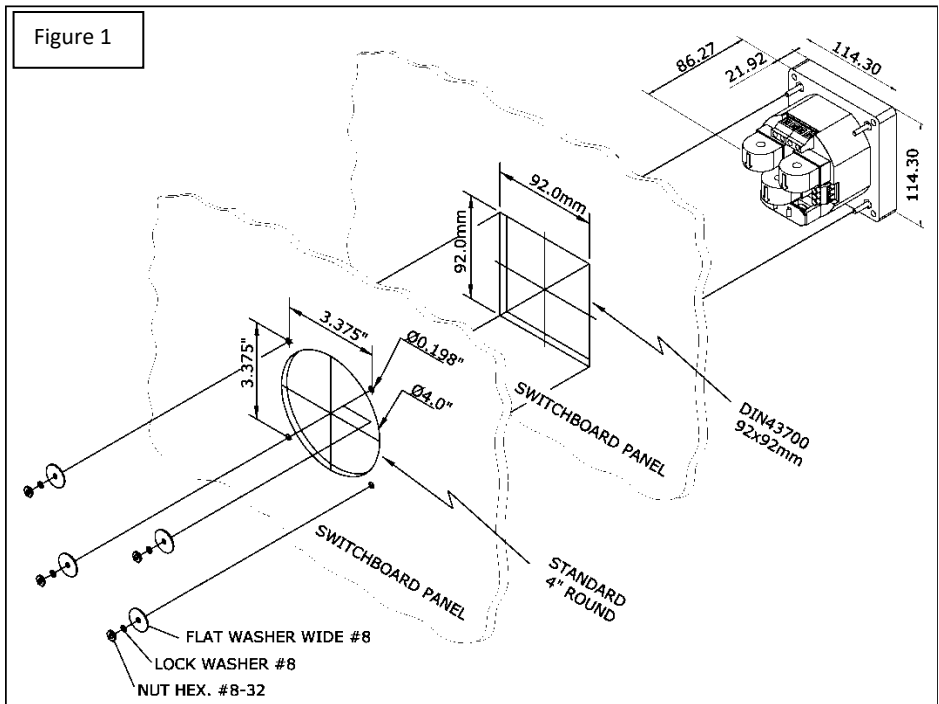

CONNECTION

To connect follow these steps (Figure 2 shows a 4W LV installation with conventional CTs):

1. Ensure that all incoming power sources are OFF.
2. Check that you have the appropriate power supply.
3. Connect the Power Supply inputs using 1.5 mm²/14AWG dedicated wires and breaker.
4. Connect to the external CTs by passing the external CTs wires through the meter CT cores. Observe the arrow that indicates the current direction (Figure 2A). For HACS: connect the red or white wire to the “-” and orange or black wire to the “+” terminal.
5. In case of a retrofit application where each external CT ends with two wires (Note 2B):
 - 5.1. Pass one wire through the meter CT core.
 - 5.2. Connect the wire to one of the meter “optional CT wire termination” screws.
 - 5.3. Connect the second wire from the external CT to the termination screw.
6. Connect the measured voltage inputs
7. Connect COM1 – RS-485 communication port
8. To connect the optional module:
 - 8.1. Make sure that the power is turned off
 - 8.2. Remove the module cover
 - 8.3. Attach the module and fasten the screws
 - 8.4. Connect the module I/O or communication (see Figure 2C for DI/O wiring)
9. Turn the power up
10. Make sure the diagnostic led is off

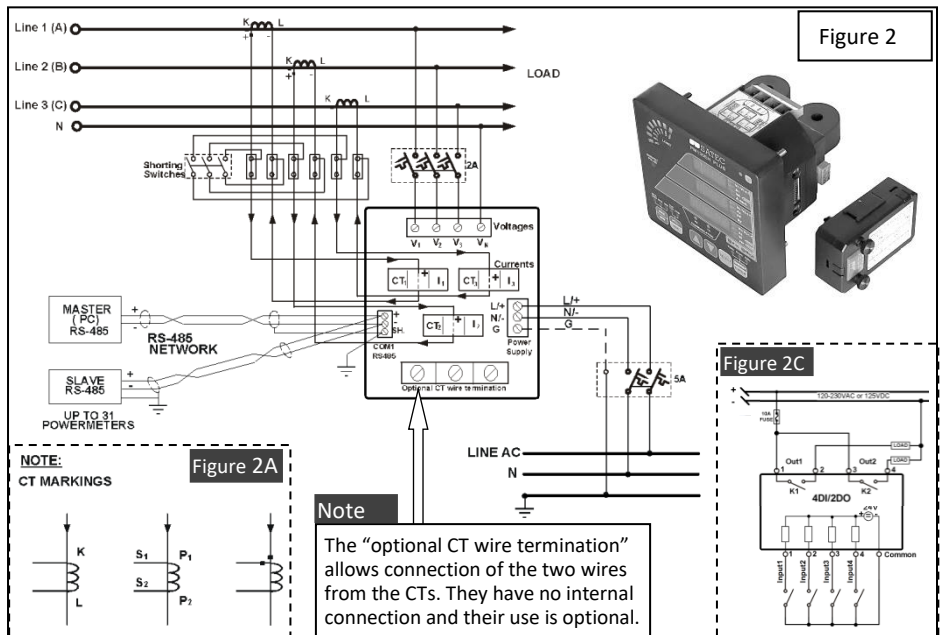

OPERATION

The PM130 PLUS is operated using the front panel which consists of a 3-line 7-segment display, up to 33 LEDs (depending on model) and six keys as shown below:

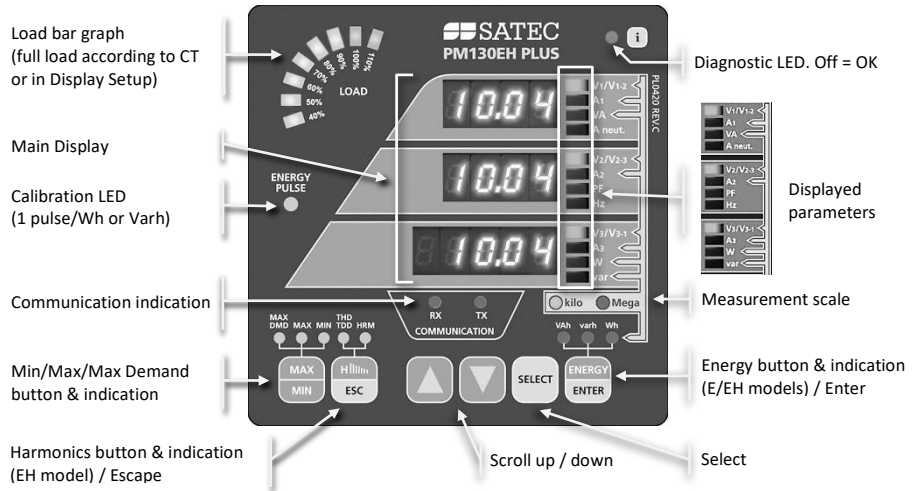

There are two display modes: readings and menus.

Readings Mode

There are four groups of readings: Common measurement, Min/Max, Harmonics and Energy. Use **MAX/MIN** or **Hllllll** or **ENERGY** to switch between groups, **▲** or **▼** to scroll within the group, or simultaneous **▲** and **▼** to go to the first screen of the current display group.

Menu Mode

Press **SELECT** to enter menu mode (blinking line indicates the selection). **SELECT** to change the selection, **ENTER** to drill down or **ESC** to go up. In editing mode use **▲** or **▼** to change the value (a number or submenu), **ENTER** to accept it, or **ESC** to cancel.

The following chart shows the structure of the menus:

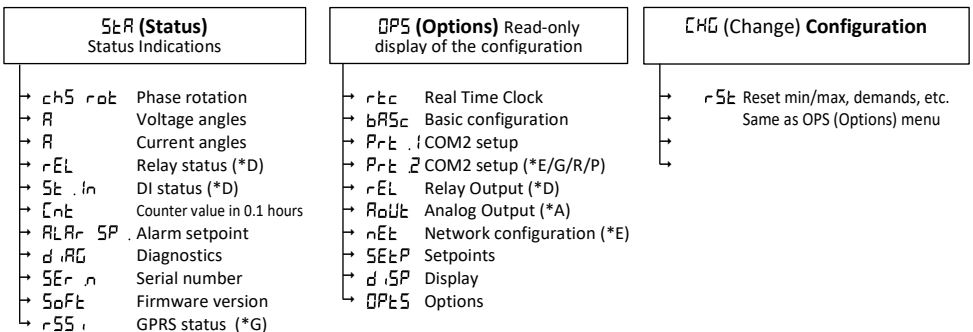

NOTE: Option availability depends on installed add-in module:

*D – Digital I/O; *A – Analog Output; *E – Ethernet; *G – GPRS; *R – RS232/422/485; *P – Profibus.

CONFIGURATION

The essential configuration includes:

1. Basic measurement setup
2. Communication setup and testing
3. Resetting the min/max, energy, demands etc.

Additional recommended configuration: set points, TOU and data logging

Note: It may be easier first to configure communication and use PAS software for setup

Basic Measurement Setup

In any display screen, press **SELECT** x 3 (until \square H \square blinks), then press **ENTER** (r5E blinks), then \blacktriangle x 2 (bRS \square) and **ENTER** to enter the Basic Settings Display.

Parameter	Description	Default
\square d n F (see below)	Network wiring configuration	4LN3
P \square	Transformation ratio of the Potential Transformers	1
P \square F	Additional PT factor for EHV network	H 1
\square E	The Primary Rating Of The Current Transformers (quick access to this parameter: press SELECT , then simultaneous \blacktriangle and SELECT)	5R
d P (E & EH models)	Duration in minutes of the power demand period calculations E = External pulse in DI1	15
n d P (E & EH models)	The number of blocks to be averaged for sliding window demands	1
R d P	Duration in seconds for voltage and current demand	900
F r E \square	The nominal frequency	60 HZ
L d R d	Max. Demand Load Current in Amperes. 0 = CT primary current.	0

Wiring Mode	Setup
3-wire 2-element Delta direct connection using 2 CTs	3d 1r2
4-wire 3-element Wye direct connection or 3PTs, and 3 CTs	4LN3 or 4LL3*
3-wire 2-element Open Delta connection using 2 PTs, 2 CTs	3OP2
4-wire 2½-element Wye connection using 2 PTs, 3 CTs	3LN3 or 3LL3*
3-wire 2½-element Open Delta connection using 2 PTs, 3 CTs	3OP3
4-wire 3-element Delta direct connection using 3 CTs	4LN3 or 4LL3*
3-wire 2½-element Broken Delta connection using 2 PTs, 3 CTs	3bLN3 or 3bLL3*

* LN or LL denotes the default use of L-L or L-N voltages (in thresholds, min/max, demands etc.)

Communication setup and testing

In any display screen, press **SELECT** x 3 (\square H \square blinks), then press **ENTER** (r5E blinks), then \blacktriangle x 3 (P r E . i) and **ENTER** to setup the built in RS-485 port (COM1).

If communication module is present, configure also COM2.

Resetting the min/max, energy, demands etc.

In any display screen, press **SELECT** x 3 (\square H \square blinks), then press **ENTER** (r5E blinks), then **ENTER** to enter the reset menu. Select the value to be reset, press **SELECT** to select, then press **ENTER** for 5 seconds until the Δ notification is changed to d d n E.