



EDL180

PORTABLE EVENT & DATA LOGGER

INSTALLATION & OPERATION MANUAL



Limited Warranty

The manufacturer offers the customer functional warranty for 36 months from the date of production. This warranty is on a return to factory basis.

The manufacturer does not accept liability for any damage caused by instrument malfunction. The manufacturer accepts no responsibility for the suitability of the instrument to the application for which it was purchased.

Failure to install, set up or operate the instrument according to the instructions herein will void the warranty.

Only a duly authorized representative of the manufacturer may open your instrument. The unit should only be opened in a fully anti-static environment. Failure to do so may damage the electronic components and will void the warranty.

The greatest care has been taken to manufacture and calibrate your instrument. However, these instructions do not cover all possible contingencies that may arise during installation, operation or maintenance, and all details and variations of this equipment are not covered by these instructions. For additional information regarding installation, operation or maintenance of this instrument, contact the manufacturer or your local representative or distributor.

For more details concerning technical assistance & support visit manufacturer's web site:

www.satec-global.com

Note:

The greatest care has been taken to manufacture and calibrate your instrument. However, these instructions do not cover all possible contingencies that may arise during installation, operation or maintenance, and not all details and variations of this equipment are covered by these instructions. For additional information regarding installation, operation or maintenance of this instrument, contact the manufacturer or your local representative or distributor.

Supplementary Instructions:

This manual provides instructions for using the EDL180. For instructions and information on using the PM180, refer to the PM180 Installation and Operation Manual; for instructions and information on using the PAS software package, refer to the PAS User's Manual included in the accompanying CD for the PM180 Series.

Contents

1. Portable Event & Data Logger	4
1.1 The EDL180 Portable Event & Data Logger	4
1.2 Internal UPS for independent power supply	4
2. Physically supplied content	4
3. Front Panel Components	5
4. Installation / wiring	6
4.1 Location	6
4.2 Power Supply and UPS Charging	6
4.3 LED Charging Indicators	6
4.4 Voltage Probes Connection	6
4.5 Current Sensors Connection	6
4.6 Standard FLEX Current Sensors	6
4.7 Configuring Wiring Mode and CT Ratings	7
4.8 Internal Uninterrupted Power Supply	8
5. Specification	8

1. Portable Event & Data Logger

1.1 The EDL180 Portable Event & Data Logger

The device records and analyzes events and data of electrical network parameters. Being mobile, it enhances efficiency by enabling onsite identification of power quality problems, the EDL180 meets the requirements of a wide range of applications, from event analysis to energy auditing and load profile recording over a set time period.

The EDL180 parameters include all the measurement and logging capabilities of the PM180 power quality analyzer in a convenient, portable case. The manufacturer's PAS software suite, available online, provides graphic data display and power quality analysis capabilities.

The EDL180 is suitable for direct measurement of voltages up to 828V AC (or greater when using a Potential Transformer). The EDL180 is provided with standard current clamps featuring a range of options between 30-3,000A AC nominal current with nominal 2V AC or 3V AC outputs.

1.2 Internal UPS for independent power supply

The EDL180 has an internal UPS providing over 4 hours of power supply during loss of external power, such as during a general power failure.

Note:

Device configuration and complementary technical specifications are identical to those of the PM180. See the PM180 Installation and Operation Manuals for full connection drawings and instructions.

2. Physically supplied content

1. EDL180 analyzer
2. Carry bag
3. Power cable (EU plug)
4. Voltage probe set: 4 colored cables (yellow, blue, red and black) with crocodile connectors
5. Flex current sensors: 4 units according to ordered model:
 - I. 30/300/3,000A model: requires battery (not supplied)
 - II. 200A model: does not require battery
6. USB cable: type A to type A

3. Front Panel Components

The manufacturer offers the customer functional warranty for 36 months from the date of production. This warranty is on a return to factory basis.

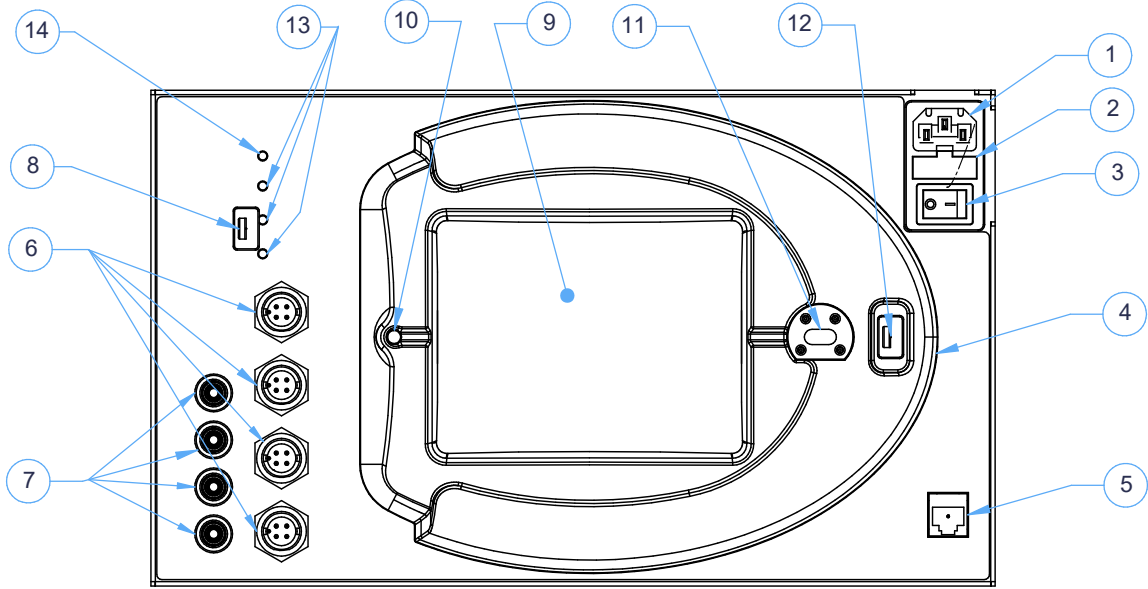

Figure 1: Front panel components, inputs and outputs

1	AC Power Supply Socket
2	Fuse
3	Power-on switch
4	RGM display module
5	ETH port
6	Current-clamp inputs
7	Voltage inputs
8	USB-A port
9	screen
10	Energy pulse LED
11	IR port
12	USB-A port
13	LED battery level indicators
14	Battery charging status LED

4. Installation / wiring

Read through this section carefully before connecting the EDL180 to the circuits being tested/analyzed.

4.1 Location

The distance between the EDL180 and the current lines must be at least half a meter (1.6 feet) for current lines carrying up to 600A, and at least one meter (3.3 feet) for currents between 600A and 3,000A.

4.2 Power Supply and UPS Charging

Connect the EDL180 to AC power supply using the Power Supply Cord provided. Turn the power switch (No. 3) ON.

Once the unit is connected to an external power supply, the UPS battery automatically starts charging, regardless of whether the unit is powered on or not.

4.3 LED Charging Indicators

The unit features 4 LEDs: 3 indicating battery level (13) and one indicating charging status (14): red = charging; blue = full.

4.4 Voltage Probes Connection

For voltage readings use the supplied voltage probes. connect the voltage probes' outputs to the EDL180 through the voltage 4mm sockets marked V1/V2/V3/VN. Connect the probes to the power line conductors according to the power system configuration / siring mode (See figure 2 below). For alternative line configurations please consult the PM180 installation manual.
WARNING: the voltage between phases (V1, V2, V3) must not exceed 828V.

4.5 Current Sensors Connection

Connect the current sensors' outputs first to the EDL180 and then to the measured circuits, by either wrapping the probe around the line or via clamp, in accordance with ordered/ supplied model.

4.6 Standard FLEX Current Sensors

The EDL180 can work with all FLEX and clamp current sensors featuring a voltage output up to 6VAC. However, for locally sourced sensors, make sure to contact the manufacturer for confirmation of compliance and instructions.

4.7 Configuring Wiring Mode

The wiring mode of the EDL180 is the same as for the PM180. See standard example below (figure 2). For alternative line configurations please refer to the PM180 Installation and PM180 Operation manuals (separate documents).

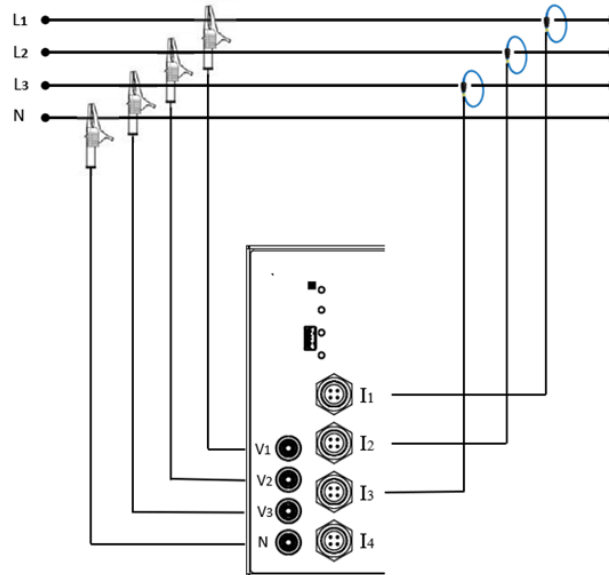

Figure 2: Four wire WYE Direct connection, using 3 CTs (3-element) wiring mode

4.8 Configuring CT values

For the coil ranging 30-3,000A AC, featuring CT ratio output of 1kA/1V AC, nominal current is determined on coil integrator by scale switch (image 3 below) and must be set in unit according to selection.

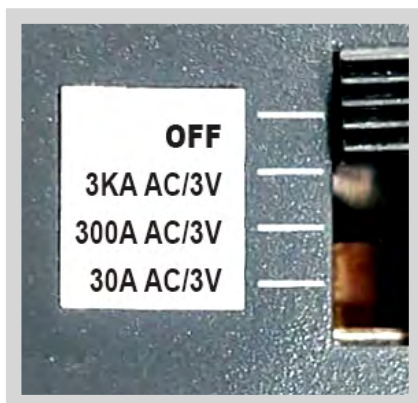

Figure 3: Rated-current Switch

to selection.

For the permanently rated 200A clamp, featuring CT ratio of 1.5kA/1V AC nominal current, nominal current must be adjusted and set at 300A and NOT at the presumed 200A.

Nominal current is set in the device either via RGM screen or via PAS as described in the manuals mentioned below.

Configuration using the RGM180 front Panel

For configuration of the wiring mode and CT values via the RGM180 front panel, refer to the Wiring Setup instructions in the RGM180 QuickStart Manual.

Configuration using PAS software

For configuration via Power Analysis Software (PAS) please refer to the above PM180 manuals.

4.8 Internal Uninterrupted Power Supply

The EDL180 includes a rechargeable UPS. When fully charged, the UPS allows the EDL180 to work for over 4 hours at maximum consumption. It is recommended to switch off the unit when not in use to prevent discharge. However, discharge has not been reported to harm the UPS battery.

5. Specifications

Power supply: 90-264V AC @ 50-60Hz

UPS Battery Pack: rechargeable; 3.7V * 15,000mAh DC. Tested for over 4 hours of power of full consumption/burden (unit + RGM screen).

UPS characteristics:

- Battery output voltage 3.7V *3 = 11.1V
- Over charge protection
- Over discharge protection
- Over current protection
- Over discharge protection
- Short protection

Accuracy: The EDL180 accuracy is set by the combined accuracies of the PM180, current clamps and the PT, if used. The common factors are the unit accuracy and that of the current clamps, which are the dominant factor.

Operation temperature: 0-60°C

Humidity: 0 to 95% non-condensing

Dimensions (facing front panel)

Height: 190 mm, (7.5"),

Width: 324 mm, (12.7")

Depth (incl. RGM screen): 325 mm, (12.8")

Unit Weight: 4.6 KG (10.2 lbs)

Unit with carry bag, voltage probes and power cord: 6.9 KG (15.2 lbs)

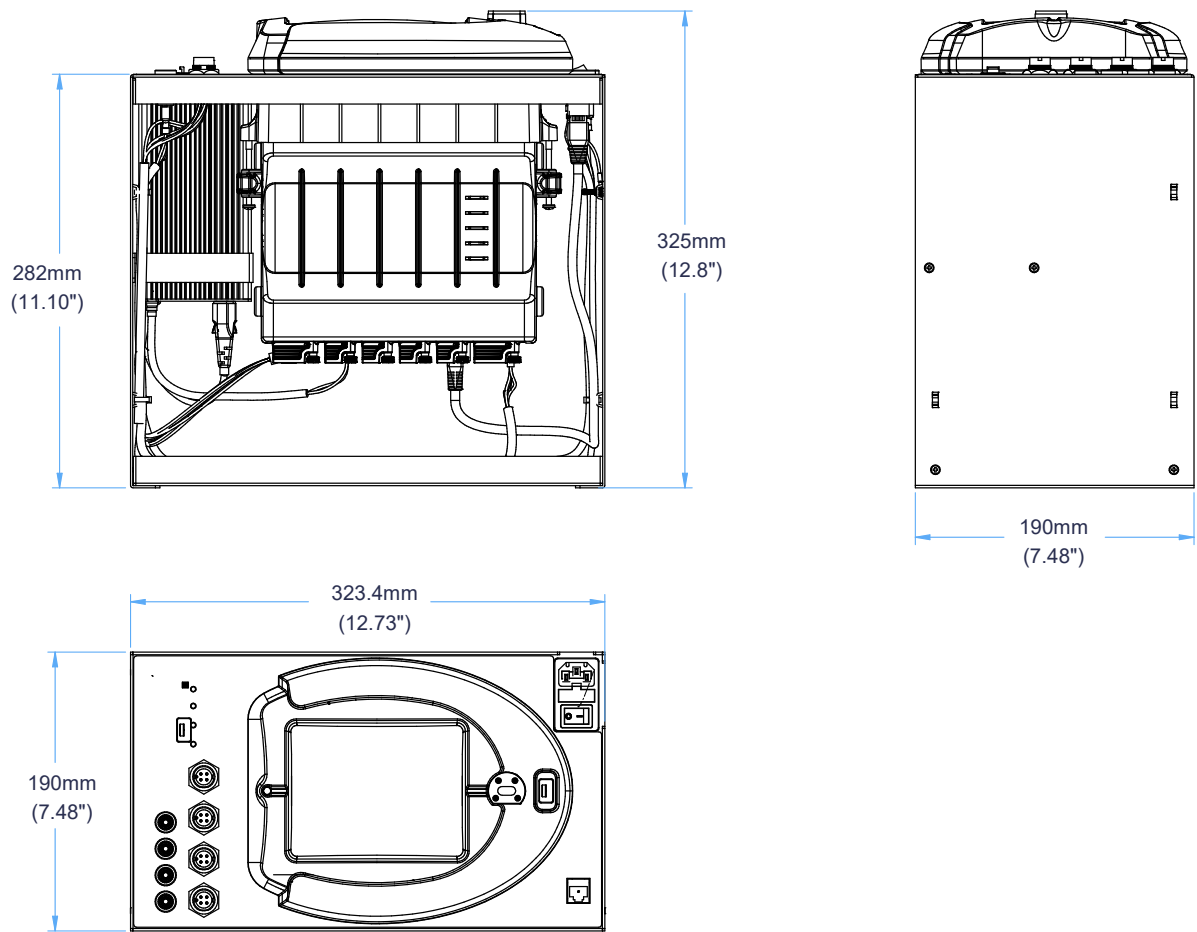

Figure 4: Device Dimensions

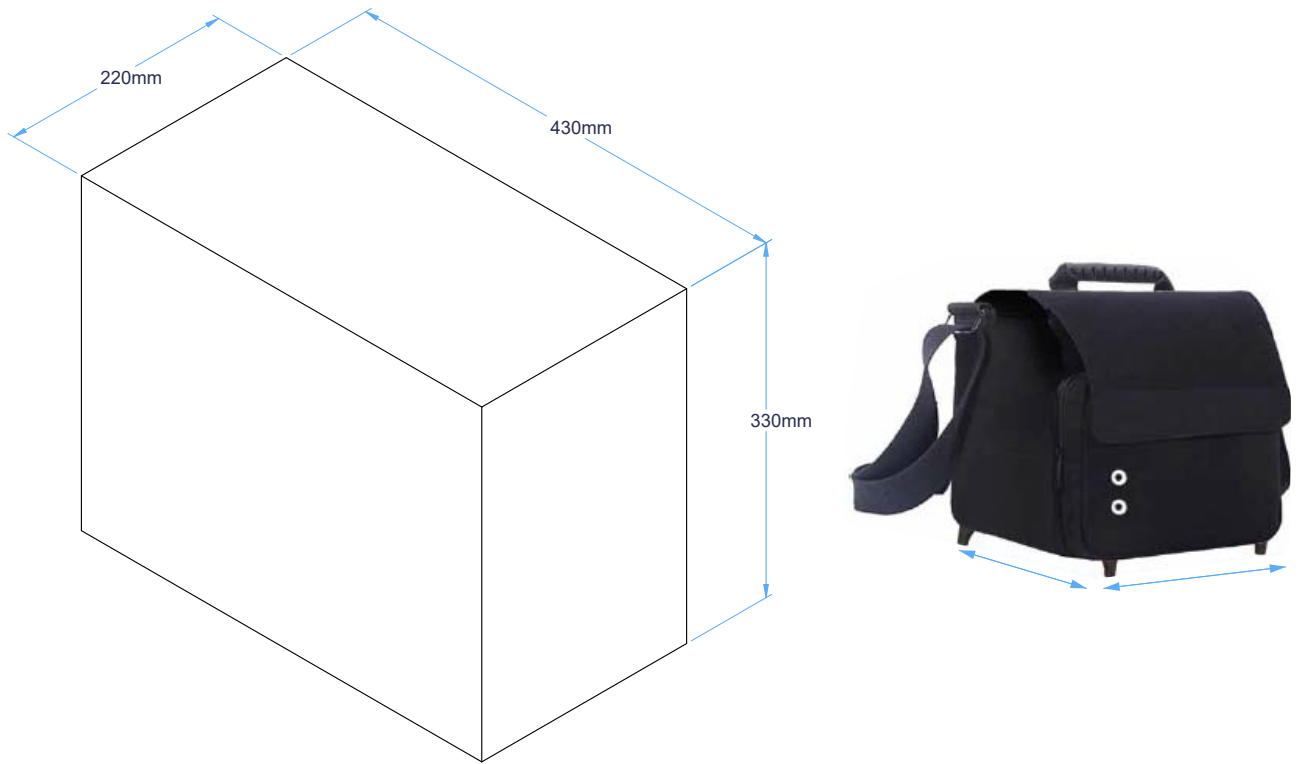

Figure 5: Bag Dimensions